

# LIR-IG89



## Weatherproof IR Illuminator



### FEATURES

- › Outdoor using
- › 20PCs Super Power Led, 850nm
- › Viewing Angle:30°, 200M IR Distance
- › Control: CDS/10LUX
- › Specialties: 2 panles or 3 panles can be available, further IR distance
- › Compatible with many famous brands of cameras, for example, Sony, Samsung



2 panles  
200M, 60°  
240M, 30°



3 panles  
200M, 90°  
280M, 60°

### DIMENSIONS

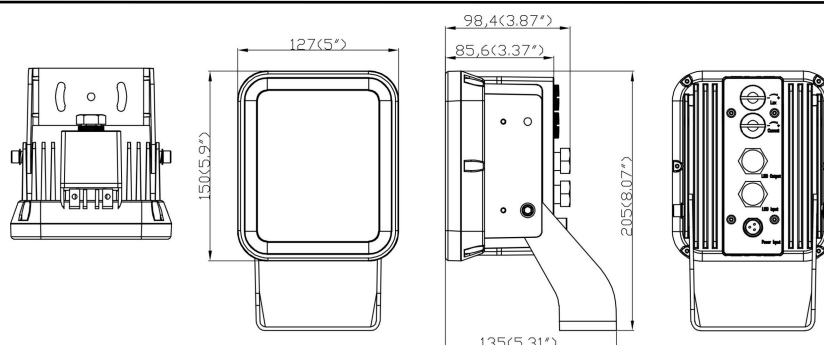

## SPECIFICATIONS

<b>IP Rating</b>	IP66
<b>LED</b>	20 Pcs Super High Powe IR LED
<b>Wave Length</b>	850nm
<b>IR Projecting Angel</b>	30°
<b>Emissive Power</b>	42W
<b>Available IR Distance</b>	200M
<b>Control</b>	CDS/10LUX
<b>Power Supply</b>	DC12V±10%/AC24V±10%
<b>Current consumption</b>	DC3000mA/AC1850mA
<b>Dimension</b>	205×127×135mm (8.2"×5"×5.31")
<b>Weight</b>	1640g
<b>Storage Temperature</b>	-30~+60°C
<b>Operating Temperature</b>	-30~+40°C
<b>Package</b>	12Pcs/CTN 23KGs 550×330×440mm(21.65"×12.99"×17.32")

4-6F No.5 Lane 130, Min-Chung Road, Hsin Tien City, Taiwan  
Room B 3rd Building of Kin On Commercial Building, Nos.51 Jervois Street, Sheung Wan, Hong Kong  
3rd~5th Floor, 2A Building, Huihao Industrial Park, He Shui Kou, Gongming, Shenzhen, China

**www.irlab.net**      **info@irlab.net**