

CIR-HBE210LHC

5 MP AHD Camera

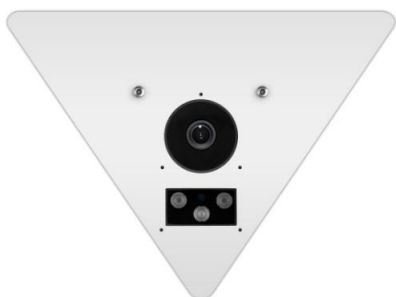

FEATURES

- 1/2.8" 5M Progressive Scan Sony CMOS
- Support four video signal output (5MP AHD / 5MP TVI / 4MP CVI / 2MP AHD / 2MP TVI / 2MP CVI / 960H CVBS), default video output is AHD
- 3PCs IR LEDs, IR Range: 10M (outdoor)
- 1.8mm IR Lens
- Feature: WDR, 3DNR, UTC, OSD

DIMENSION

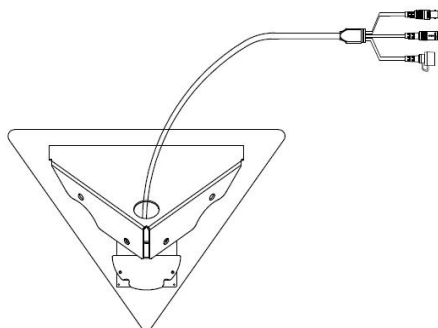
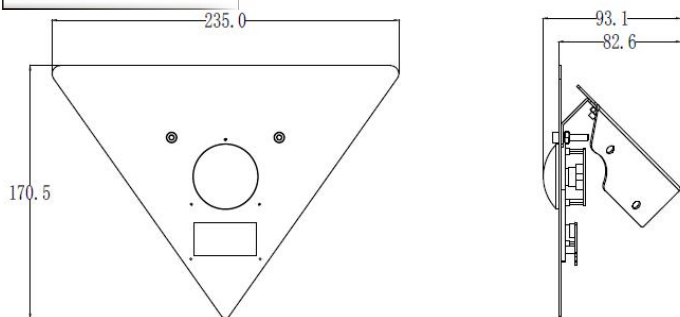

SPECIFICATIONS

CIR-HBE210LHC	
IP Rating	
Filter	Removable IR Cut Filter
Image Sensor	1/2.8" 5M Progressive Scan Sony CMOS
Pixels	2688(H)×1944(V)
Horizontal Resolution	5MP
Minimum Lux	0Lux(3 Pieces IR LED ON)
Vertical Frequency	NTSC:60Hz PAL:50Hz
Scanning System	Progressive
S/N Ratio	≥54dB
Lens	1.8mm IR Lens
White Balance	ATW
AUTO Gain Control	ON
OSD	YES
3DNR	OFF/ON
WDR	OFF/ON
Day&Night	AUTO/Color/BW/Ext
Available IR Distance	10M
Video Output	HD-AHD(TVI / CVI / CVBS)
Power Supply	DC12V±10%
Current consumption	450mA (MAX)
Dimension	235×170.5×93.1mm
Weight	850g
Storage Temperature	-30 ~ +60°C
Operating Temperature	-30 ~ +40°C

4-6F No.5 Lane 130, Min-Chung Road, Hsin Tien City, Taiwan
Room B 3rd Building of Kin On Commercial Building, Nos.51 Jervois Street, Sheung Wan, Hong Kong
3rd~5th Floor, 2A Building, Huihao Industrial Park, He Shui Kou, Gongming, Shenzhen, China

www.irlab.net

info@irlab.net