

5 MP AHD Camera



FEATURES

- 1/2.9" 5M Progressive Scan CMOS
- support four video signal output(5MP AHD / 5MP TVI / 4MP CVI / 1080P/960H CVBS), default video output is AHD
- Support Dip switch for signal changes
- 3PCs Super High Power IR LEDs, IR Range: 15M(Outdoor)
- 3.6mm IR Lens
- Feature: DWDR, DNR, UTC, OSD, MIRROR, BLC

DIMENSION

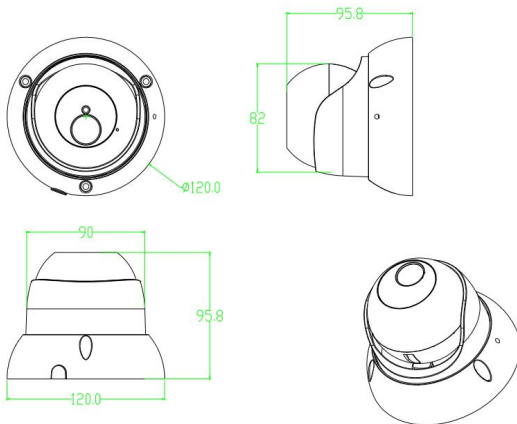

SPECIFICATIONS	
CIR-HBA4HKFC	
IP Rating	IP66
Filter	Removable IR Cut Filter
Image Sensor	1/2.9" 5M Progressive Scan CMOS
Pixels	2592(H)×1944(V)
Horizontal Resolution	5MP
Minimum Lux	0Lux(3PCs Super High Power IR LEDs ON)
Vertical Frequency	NTSC:60Hz PAL:50Hz
Scanning System	Progressive
S/N Ratio	≥52dB
Lens	3.6mm IR Lens
White Balance	ATW/MWB
MIRROR	DEFAULT / H / V / HV
OSD	YES
DNR	OFF/ON
DWDR	OFF/ON
Day&Night	AUTO/Color/BW/Ext
Available IR Distance	15M
Video Output	HD-AHD (TVI / CVI / CVBS)
Power Supply	DC12V±10%
Current consumption	320mA (MAX)
Dimension	Ø120×95.8mm
Weight	600g
Storage Temperature	-30 ~ +60°C
Operating Temperature	-30 ~ +40°C